

Waterproof DMX512 Signal Amplifier/Repeater

09.02100W.04028



Important: Read All Instructions Prior to Installation

Function introduction

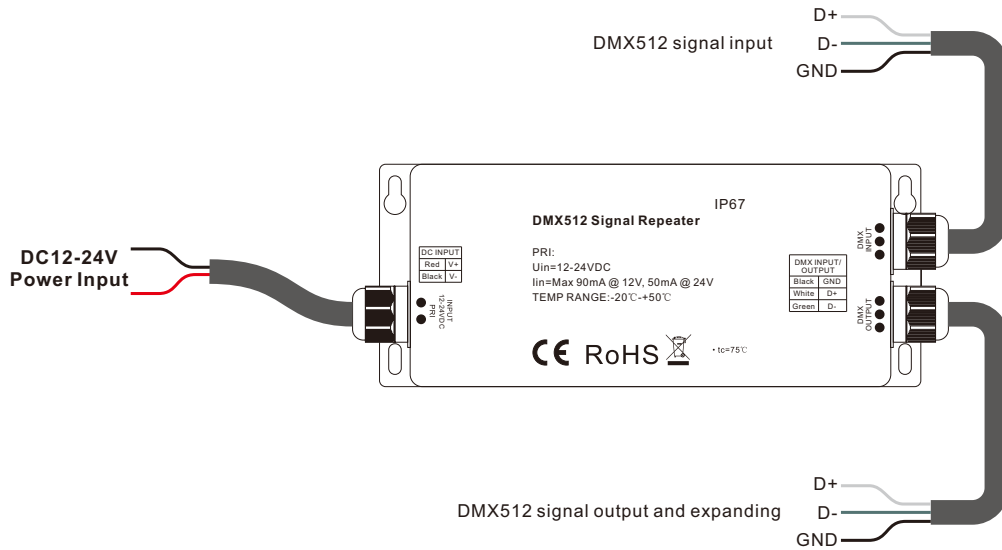

Product Data

Input Voltage	Input Current	Output	Size(LxWxH)
12-24VDC	Max 90mA @ 12V, 50mA @ 24V	DMX512 signal	180.5x73.6x38mm

- DMX signal input & output
- Work with DMX series controller to expand DMX signal based on the actual lighting projects.
- Waterproof grade: IP67

Safety & Warnings

- DO NOT install with power applied to device.
- This device is IP67 rating and protected against damp environment.

Wiring Diagram

DMX512 signal input

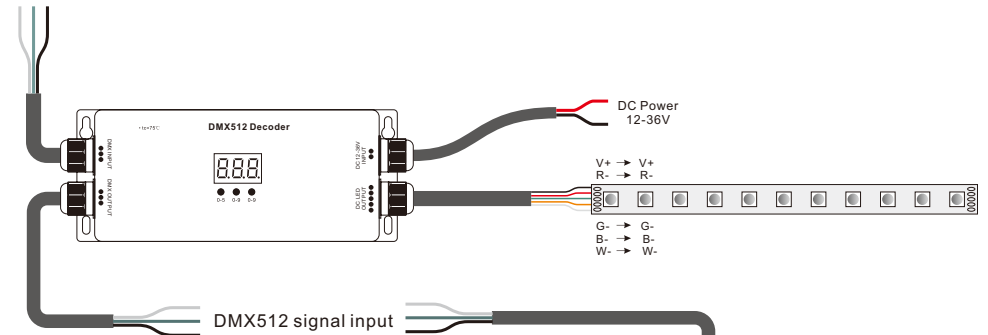

DC12-24V Power Input

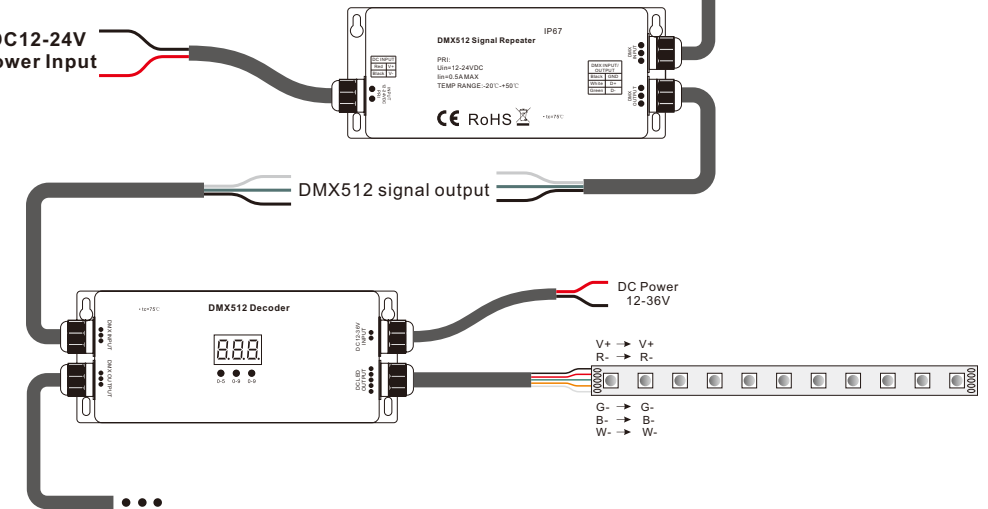

Note: Each amplifier can repeat signal for max. 12pcs DMX512 decoders in parallel within 100m range. More amplifiers are required if there are more than 12pcs decoders and the distance is further than 100m.

Product Dimension

